

# 调查研究

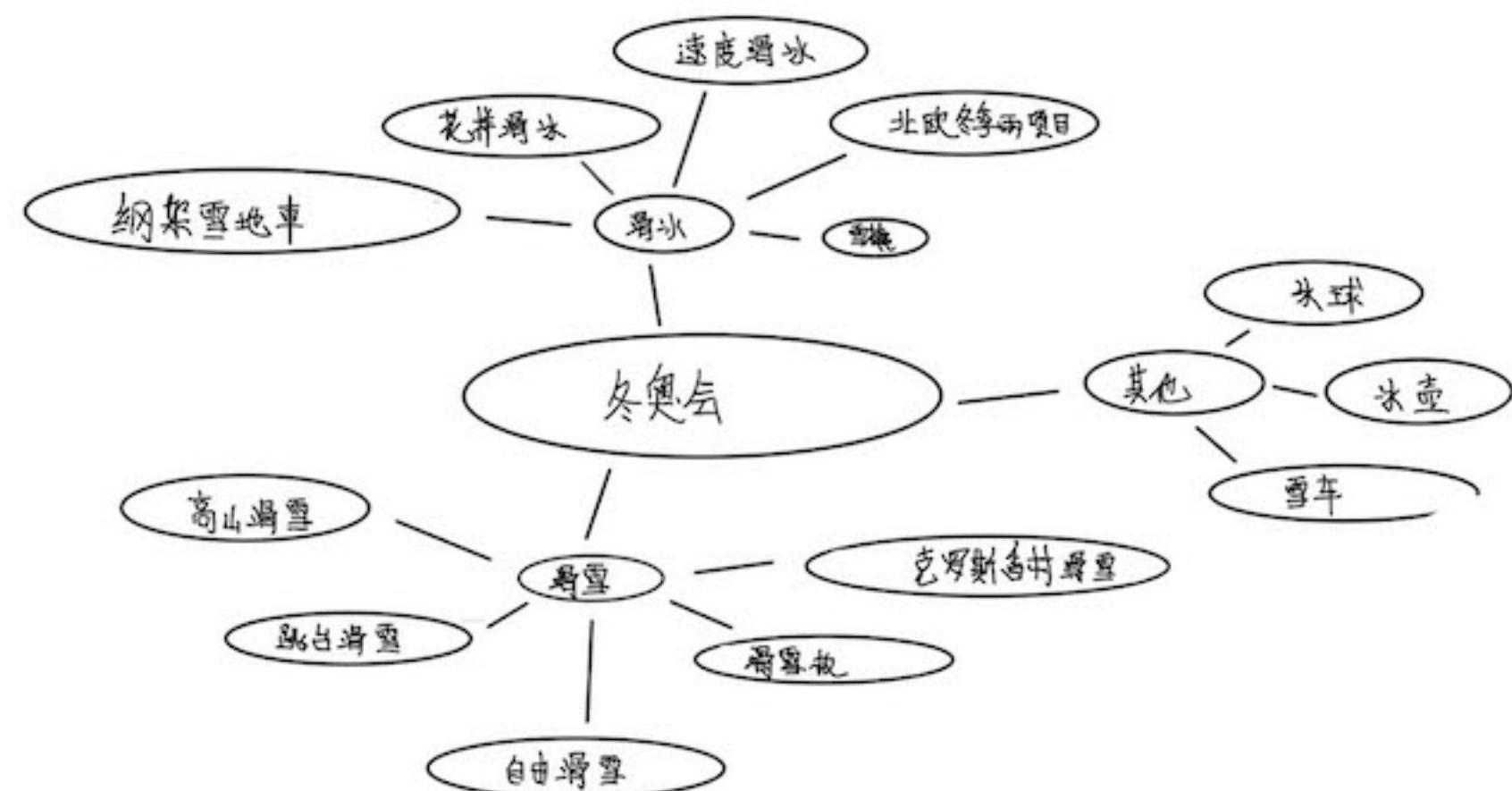

## 花样滑冰

单人



双人



运动员用冰刀在冰上画人物，并进行跳跃和旋转等困难动作

### 三字步



### 旋转步



### 苞步



### 前方交叉



### 内刃开口莫霍克台阶

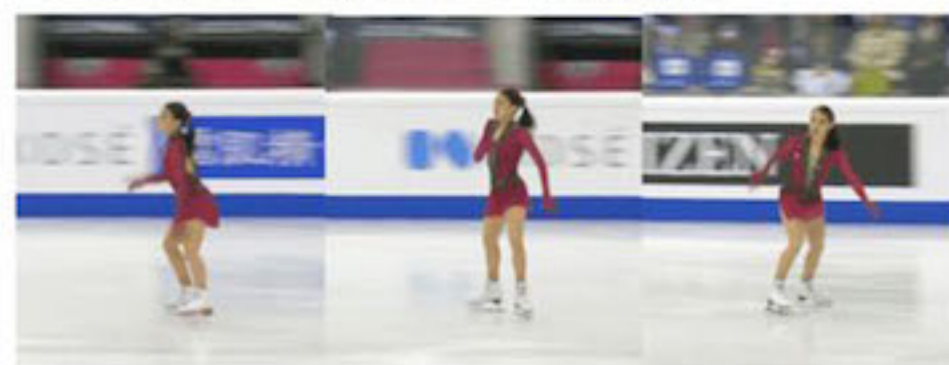

### 猛冲

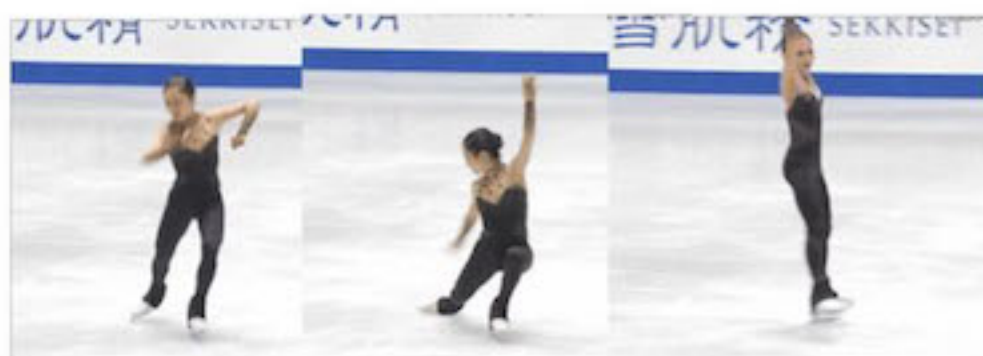

### 抽插



### 国家滑梯中心



位于北京市延庆区西大庄科村，是摩托雪橇比赛场地

### 离开区域



### 结束区域



# 形态

来自于选手比赛中的姿态

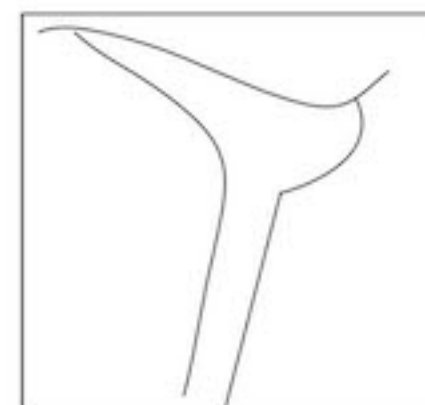
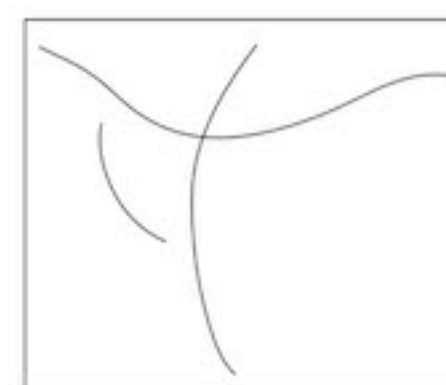
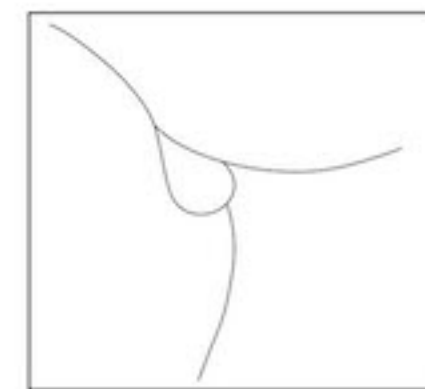
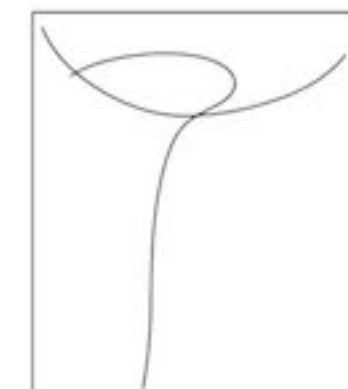
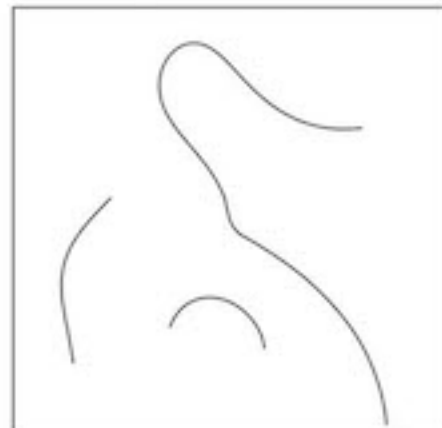
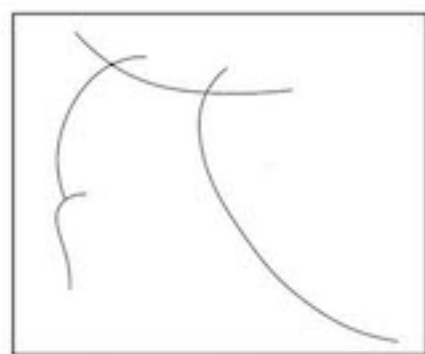
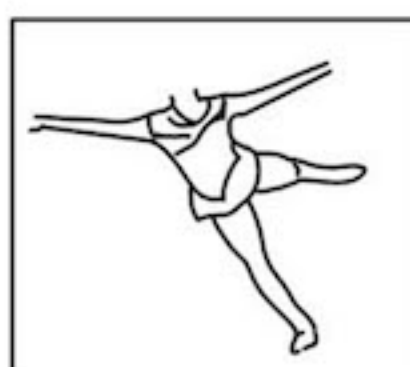
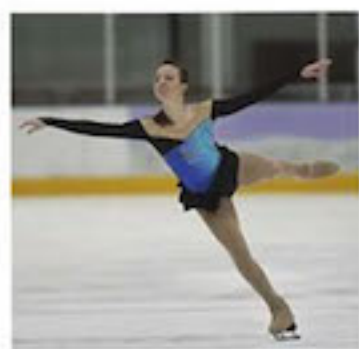
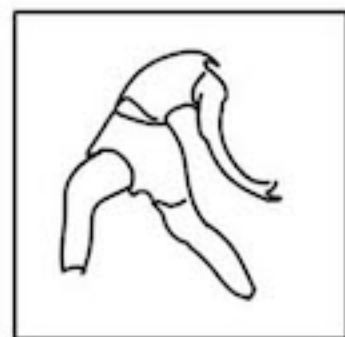
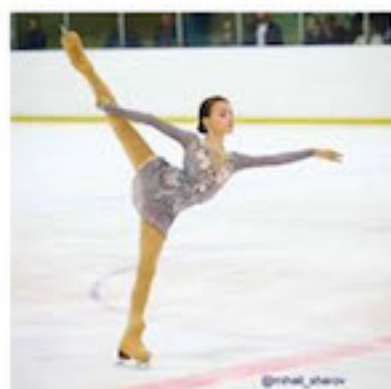

调查

利用这些形态去做设计间断

冰滑道

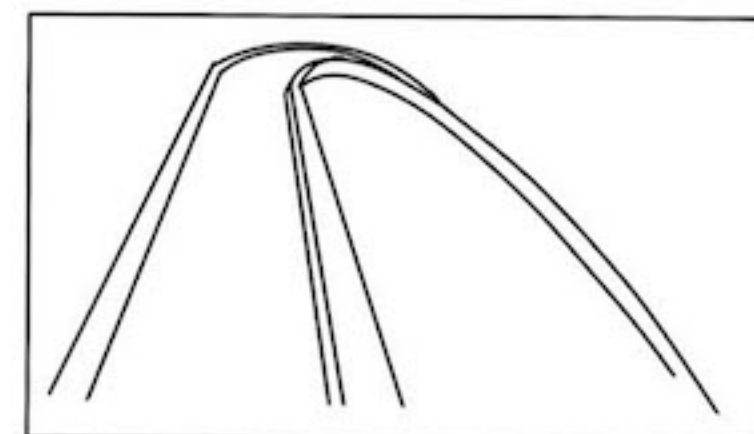
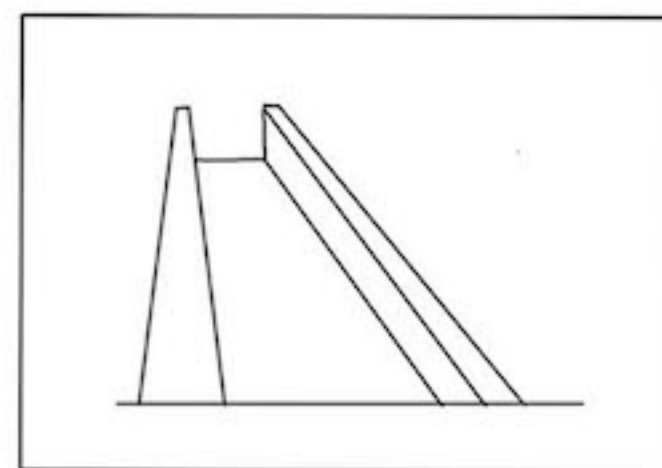

设计：

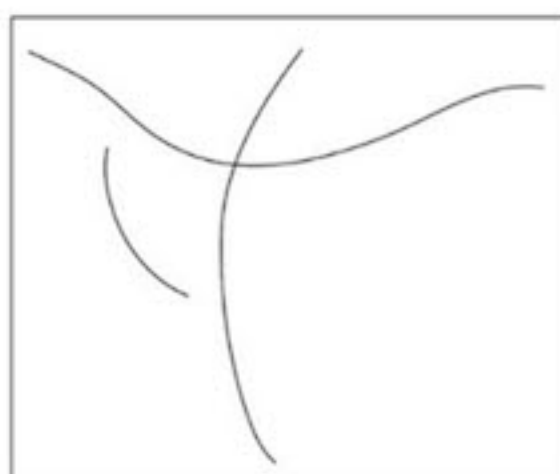

设计冰滑道，  
能让人感受运动员滑到的感觉。

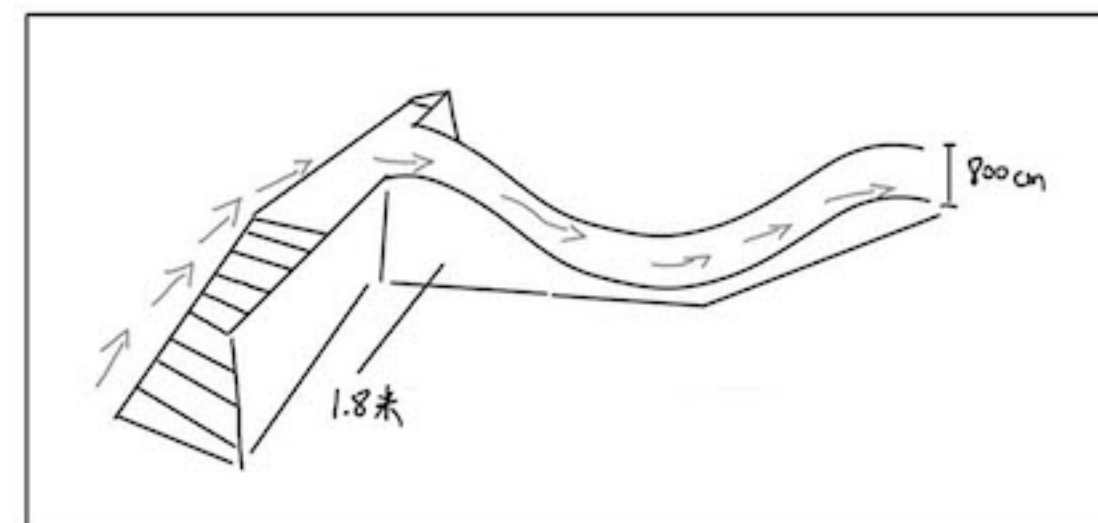

# 选址

plan

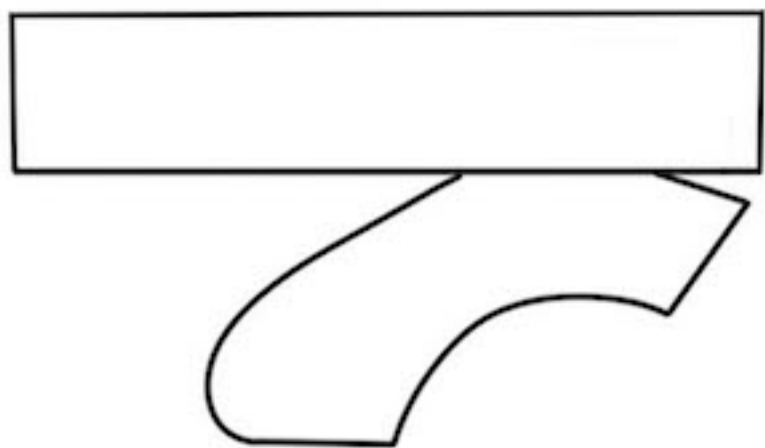

site

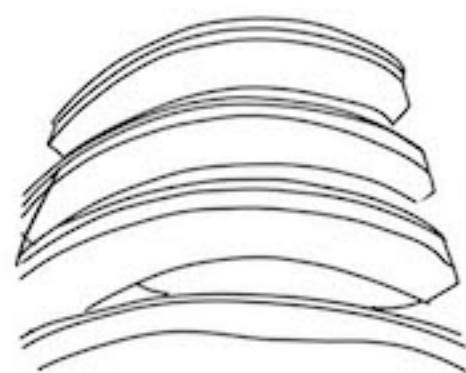
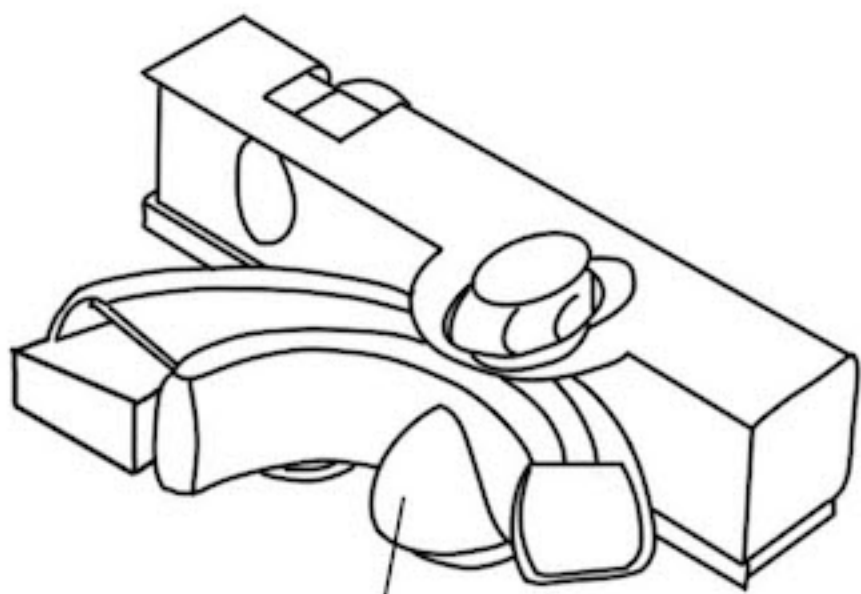

想法

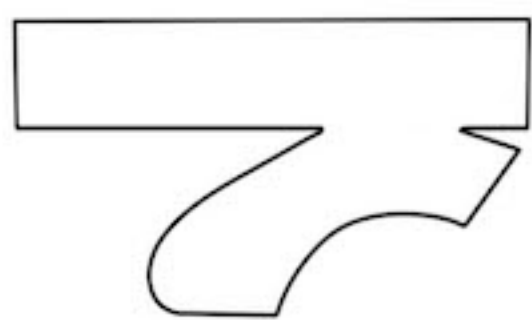

第二、三層

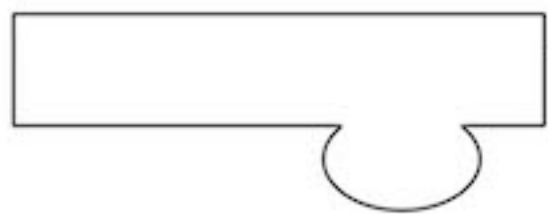

第一層

一娱乐区 每个人 (大通道)

一体验区 不会滑冰的, 平衡差的.

① (小通道), 类似单杠, 扶手 (两旁).

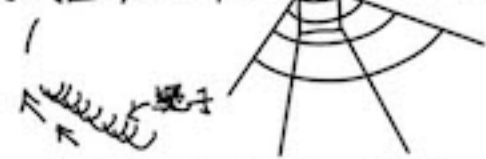

可以利用一跟一跟的绳子去平衡.

② 橡皮圈体验

「啊」, 橡皮圈水就会起泡泡  
- 这个是可以让人们体验踩在泡泡上面, 在不同的材料体验一样的感觉.

如有六个区: 娱乐区, 练习区, 学习区, 体验区, 休息区, 文化推广区.

一学习区 (技巧)

选择: 简单, 中等, 困难  
单人和双人的

} 有老师教学

一练习区

练习内容基本的滑冰 (大通道)

} 体验定会有证书和拍照留念

一休息区

最累的定脚, 所以会有

概念



占比:



娱乐区: 60%  
体验区: 40%  
练习区: 20%  
学习区: 20%  
休息区: 60%  
文化推广区: 4%

洗手间 → 每一层都有



厚度: 3-5cm 30米

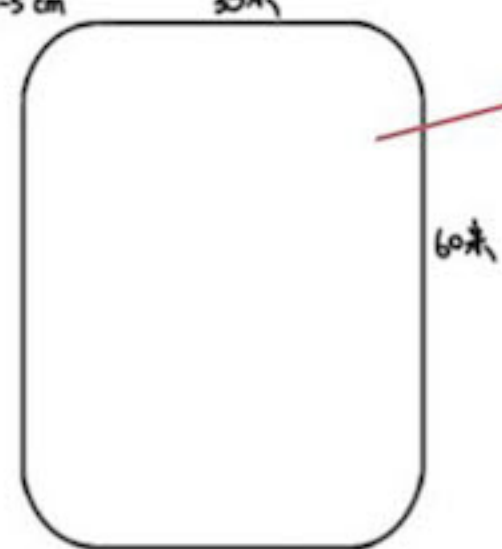

这个冰地打算用透明色基来做, 模拟冰地.



透明色基.

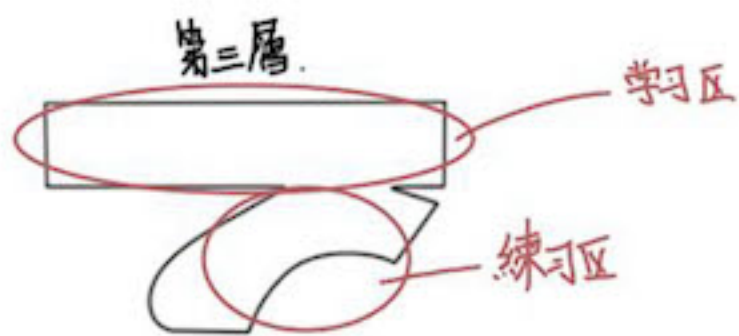
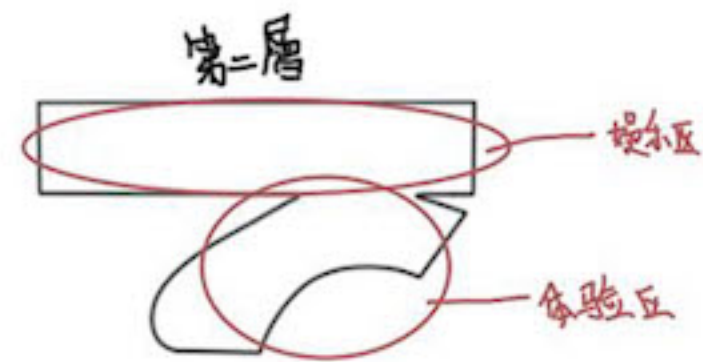
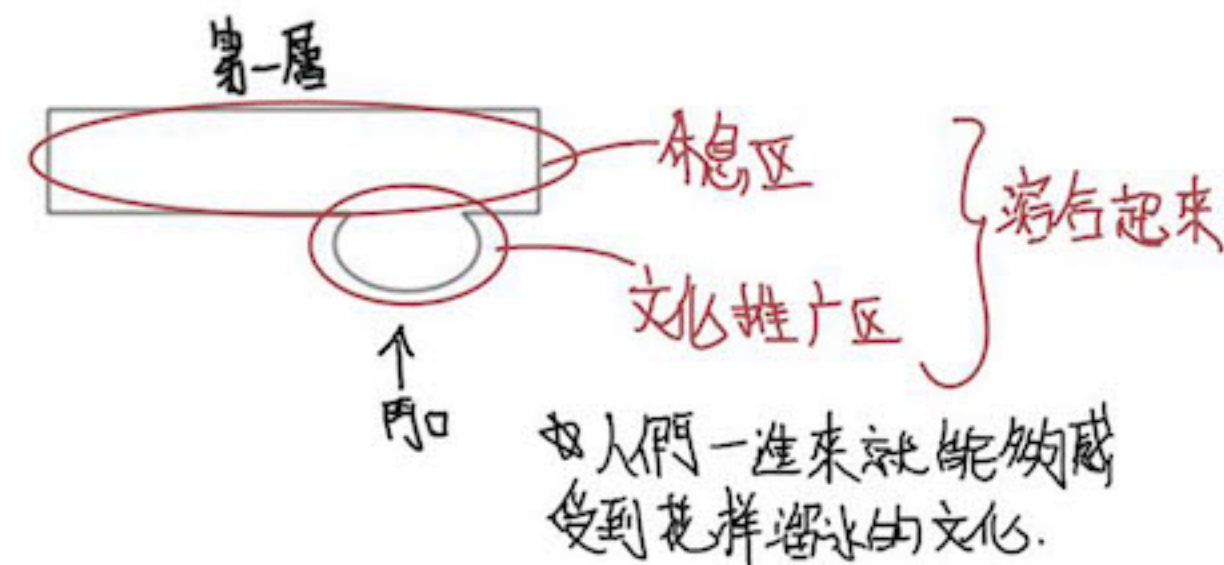

# 设计方案



肥皂是一种传统的洗涤产品，  
在每个家庭中都被广泛使用，  
对一些人来说，它仍然是一种必需品

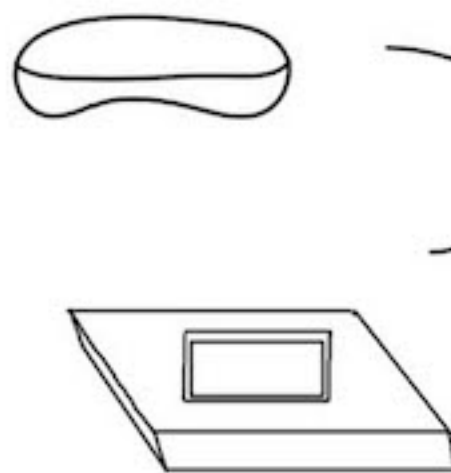

肥皂有很多形状，最常见就是这两个。



肥皂遇到水之后就会变得很滑，  
就会产生泡泡。

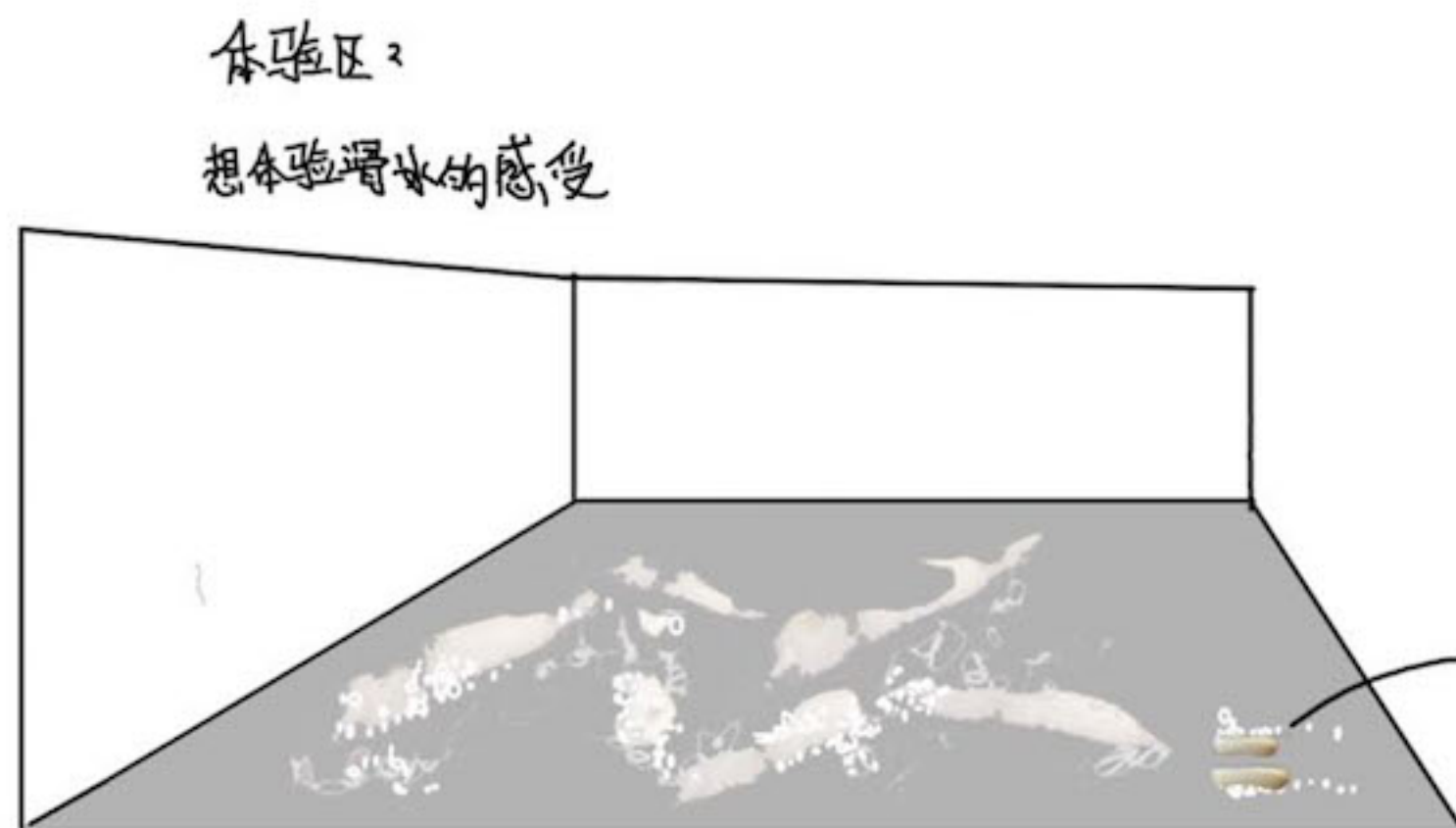

体验区：

想体验滑冰的感受

当香皂作为鞋子

平面图：

一楼

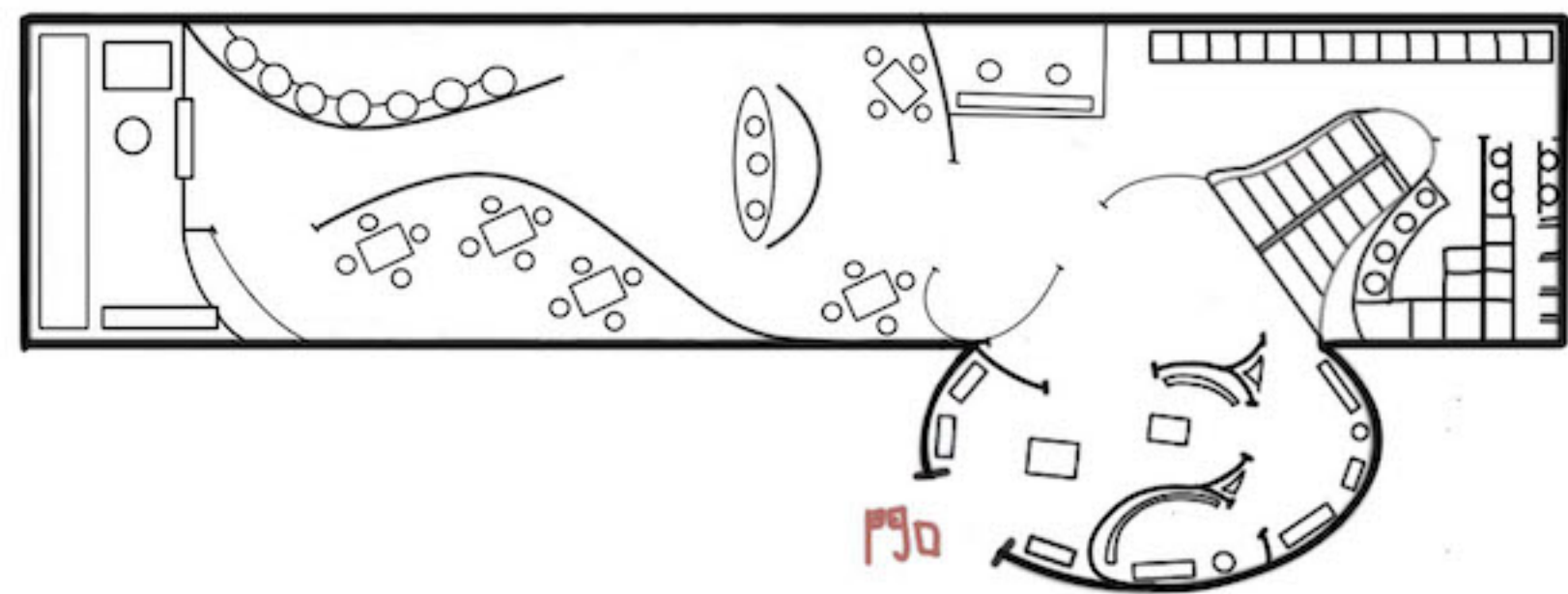

二楼

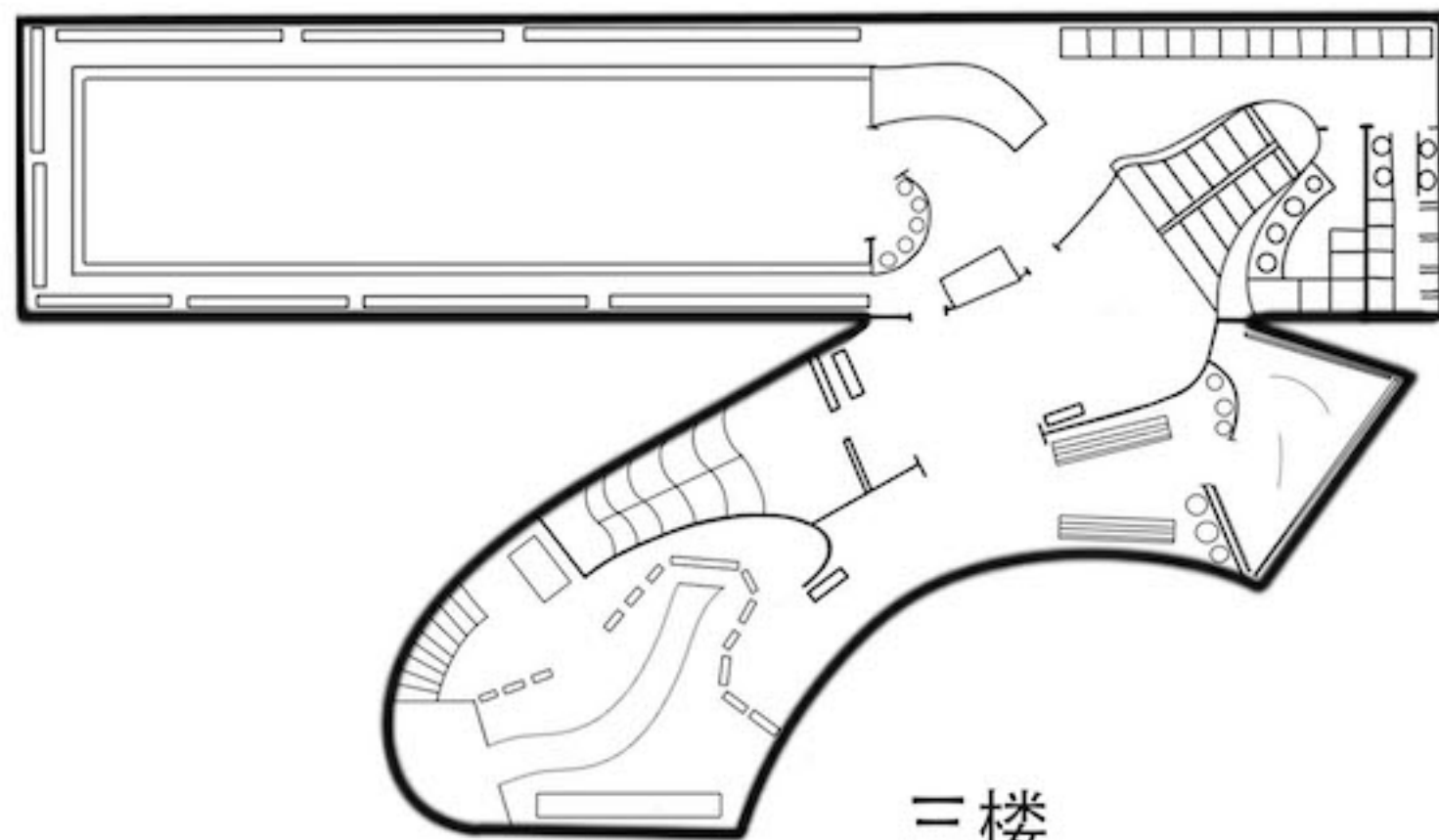

三楼

